

Features

- InGaAs technology
- 7.1 mm² PIN detector
- High sensitivity up to 1700 nm
- Low dark current

Description

Low dark current InGaAs PIN photodiode with circular 7.1 mm² active area. Metal can type hermetic and insulated TO5i package with clear glass window.

Application

- Precision photometry
- Analytical instruments
- Medical equipment
- Pulsed light detector
- Eyesafe laser light detector

RoHS

2002/95/EC



Absolute maximum ratings

Symbol	Parameter	Min	Max	Unit
T _{STG}	Storage temp	-40	85	°C
T _{OP}	Operating temp	-20	85	°C
V _{max}	Max reverse voltage		20	V
I _{PEAK}	Peak DC current		10	mA

Spectral response

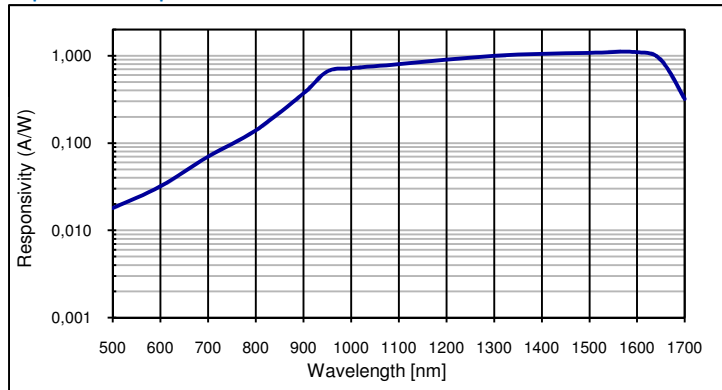

Schematic

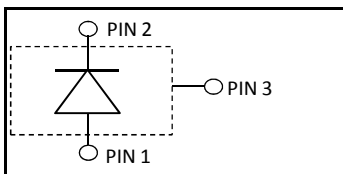

Electro-optical characteristics @ 23°C

Symbol	Characteristic	Test Condition	Min	Typ	Max	Unit
	Active area		diameter 3000			µm
	Active area		7.07			mm ²
I _D	Dark current	V _R = 5 V		15	100	nA
C	Capacitance	V _R = 0 V		1800	3.000	pF
		V _R = 5 V		700	1.400	pF
	Responsivity	λ = 650 nm	0.02	0.05		A/W
		λ = 850 nm	0.10	0.20		A/W
		λ = 1310 nm	0.80	0.90		A/W
		λ = 1550 nm	0.85	0.95		A/W
t _R	Rise time	V _R = 5 V; λ = 1550 nm; R _L = 50 Ω		180		ns
	Shunt Resistance	V _R = 5 mV	2	10		MΩ
	Saturation power	V _R = 0 V; λ = 1550 nm; R _L = 50 Ω		2		dbm
D*	Detectivity	V _R = 0 V; λ = 1550 nm; R _L = 50 Ω	2.5 E12	5 E12		Jones
V _{BR}	Breakdown voltage	I _R = 2 µA	20	30		V

European, International Sales:



Silicon Sensor International AG
 Peter-Behrens-Strasse 15
 12459 Berlin
 Germany
 Phone: +49-30-6399-2399
 Fax: +49-30-6399-23752
 E-Mail: sales@silicon-sensor.com

USA:



Pacific Silicon Sensor, Inc.
 5700 Corsa Avenue #105
 Westlake Village
 CA 91362 USA
 Phone: +1-818-706-3400
 Fax: +1-818-889-7053
 E-Mail: sales@pacific-sensor.com

Quantum efficiency (23 °C)

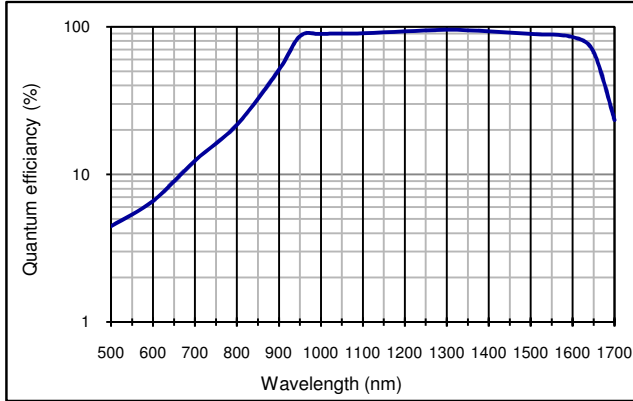

Capacitance as fct of reverse bias (23 °C)

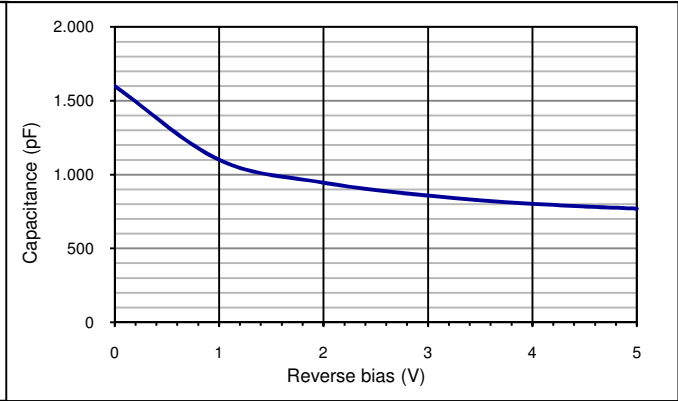

Dark current as fct of bias (23 °C)

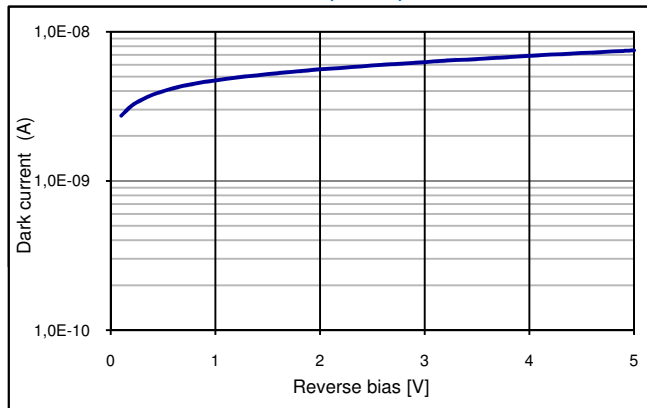

European, International Sales:



International AG

Silicon Sensor International AG
 Peter-Behrens-Strasse 15
 12459 Berlin
 Germany
 Phone: +49-30-6399-2399
 Fax: +49-30-6399-23752
 E-Mail: sales@silicon-sensor.com

USA:



Pacific Silicon Sensor, Inc.
 5700 Corsa Avenue #105
 Westlake Village
 CA 91362 USA
 Phone: +1-818-706-3400
 Fax: +1-818-889-7053
 E-Mail: sales@pacific-sensor.com

Package: TO5i

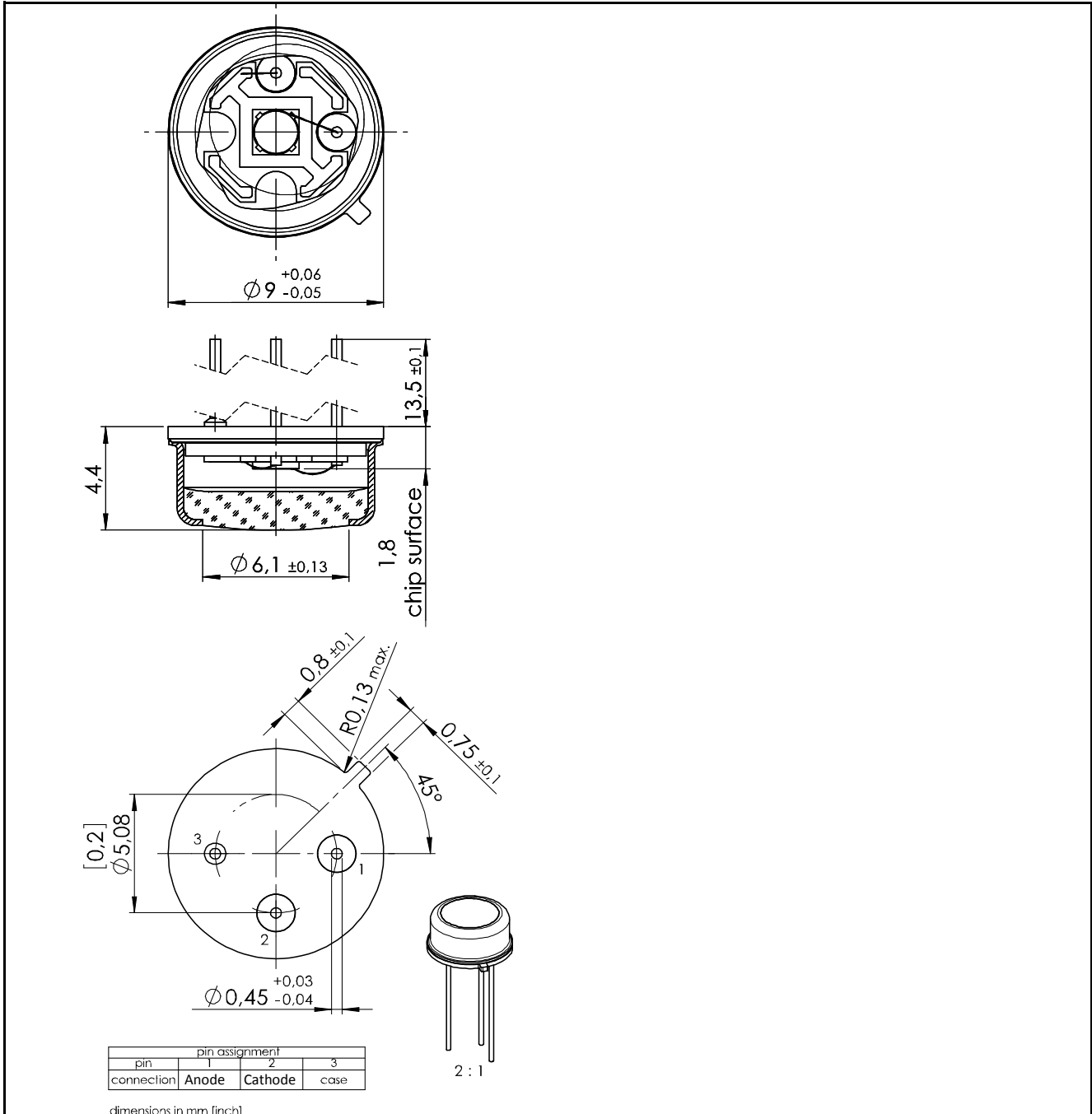

Package dimension:

Small quantities: Foam pad, boxed (12 cm x 16.5 cm)

Disclaimer: Due to our strive for continuous improvement, specifications are subject to change within our PCN policy according to JESD46C.

European, International Sales:



International AG

Silicon Sensor International AG
 Peter-Behrens-Strasse 15
 12459 Berlin
 Germany
 Phone: +49-30-6399-2399
 Fax: +49-30-6399-23752
 E-Mail: sales@silicon-sensor.com

USA:



Pacific Silicon Sensor, Inc.
 5700 Corsa Avenue #105
 Westlake Village
 CA 91362 USA
 Phone: +1-818-706-3400
 Fax: +1-818-889-7053
 E-Mail: sales@pacific-sensor.com