

Features

- ϕ 4 mm total active area
- Segmented in 4 quadrants
- Slow multiplication curve
- QE > 80% @ 750 nm-910 nm
- Fast rise time, very low noise

Description

Segmented quadrant avalanche photodiode with enhanced NIR responsivity in hermetic TO type metal can. Very low dark current due to guard ring diode.

Application

- Pulsed 905nm laser detection
- Light source positioning
- Laser alignment

RoHS

2002/95/EC



Absolute maximum ratings

Symbol	Parameter	Min	Max	Unit
T_{STG}	Storage temp	-55	125	$^{\circ}C$
T_{OP}	Operating temp	-40	100	$^{\circ}C$
M_{max}	Gain ($I_{PO} = 1$ nA)	200		
I_{PEAK}	Peak DC current		0.25	mA

Spectral response (M = 100; 22 $^{\circ}C$)

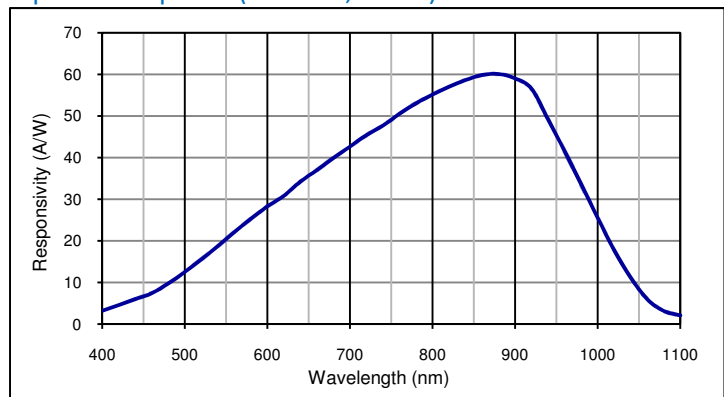

Schematic

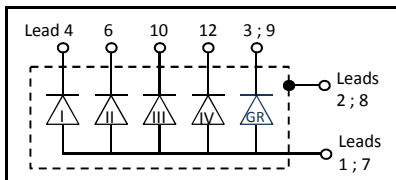

Electro-optical characteristics @ 22 $^{\circ}C$

Symbol	Characteristic	Test Condition	Min	Typ	Max	Unit
	No of elements			4		
	Active area	segmented in 4 quadrants		ϕ 4000		μm
	Gap			110		μm
I_D	Dark current	M = 100; $\lambda = 905$ nm, per segment		4		nA
C	Capacitance	M = 100, per segment		7		pF
	Responsivity	M = 100; $\lambda = 905$ nm	55	60		A/W
t_R	Rise time	M = 100; $\lambda = 905$ nm; $R_L = 50 \Omega$		2		ns
V_{BR}	Breakdown voltage	$I_R = 2 \mu A$	160		240	V
	Temperature coefficient	Change of V_{BR} with temperature	1.25		1.55	V/K
	Excess noise factor	M = 100		2.5		
	N.E.P.	M = 100; $\lambda = 905$ nm		8 E-14		W/ \sqrt{Hz}
	Photo current uniformity	M = 100		± 5		%
	Dark current uniformity	M = 100		± 5		%

European, International Sales:



International AG

Silicon Sensor International AG
 Peter-Behrens-Strasse 15
 12459 Berlin
 Germany
 Phone: +49-30-6399-2399
 Fax: +49-30-6399-23752
 E-Mail: sales@silicon-sensor.com

USA:



Pacific Silicon Sensor, Inc.
 5700 Corsa Avenue #105
 Westlake Village
 CA 91362 USA
 Phone: +1-818-706-3400
 Fax: +1-818-889-7053
 E-Mail: sales@pacific-sensor.com

Quantum efficiency (22 °C)

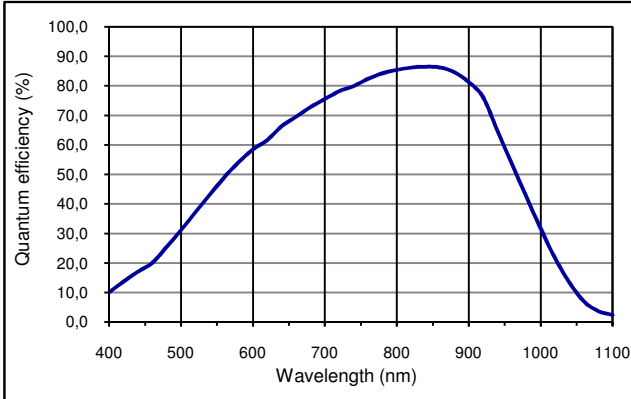

Capacitance as fct of reverse bias (22°C, per segment)

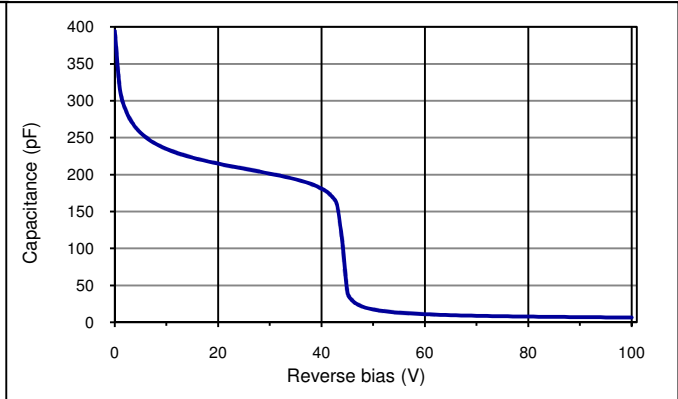

Multiplication as fct of reverse bias

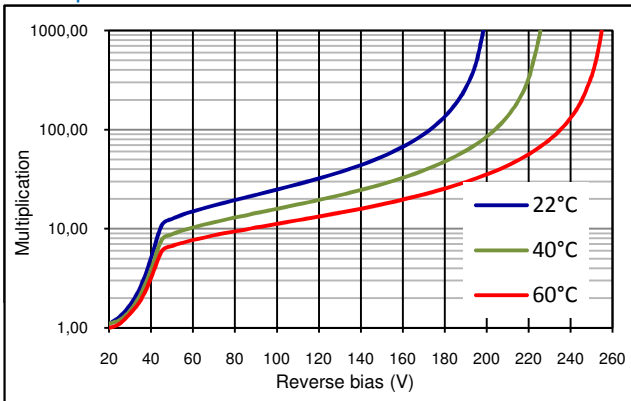

Dark current as fct of reverse bias (per segment)

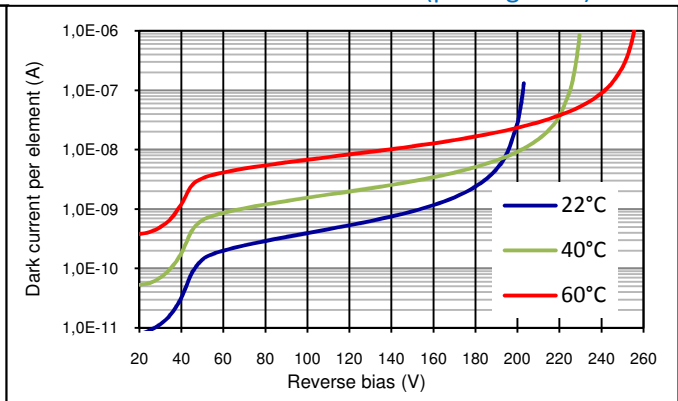

Application hints:

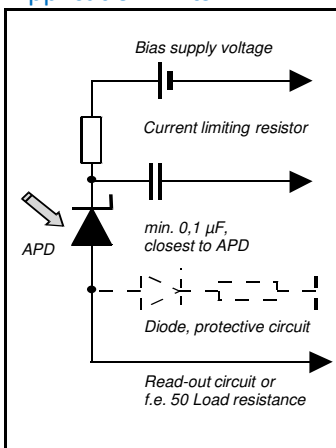

- Current should be limited by a protecting resistor or current limiting - IC inside the power supply
- For low light level applications blocking of ambient light should be used
- For high gain applications bias voltage should be temperature compensated
- Please consider basic ESD protection while handling
- Use low noise read-out - IC
- For further questions please refer to document "Instructions for handling and processing"

European, International Sales:

USA:

Technical Drawing, Package: TO8Si

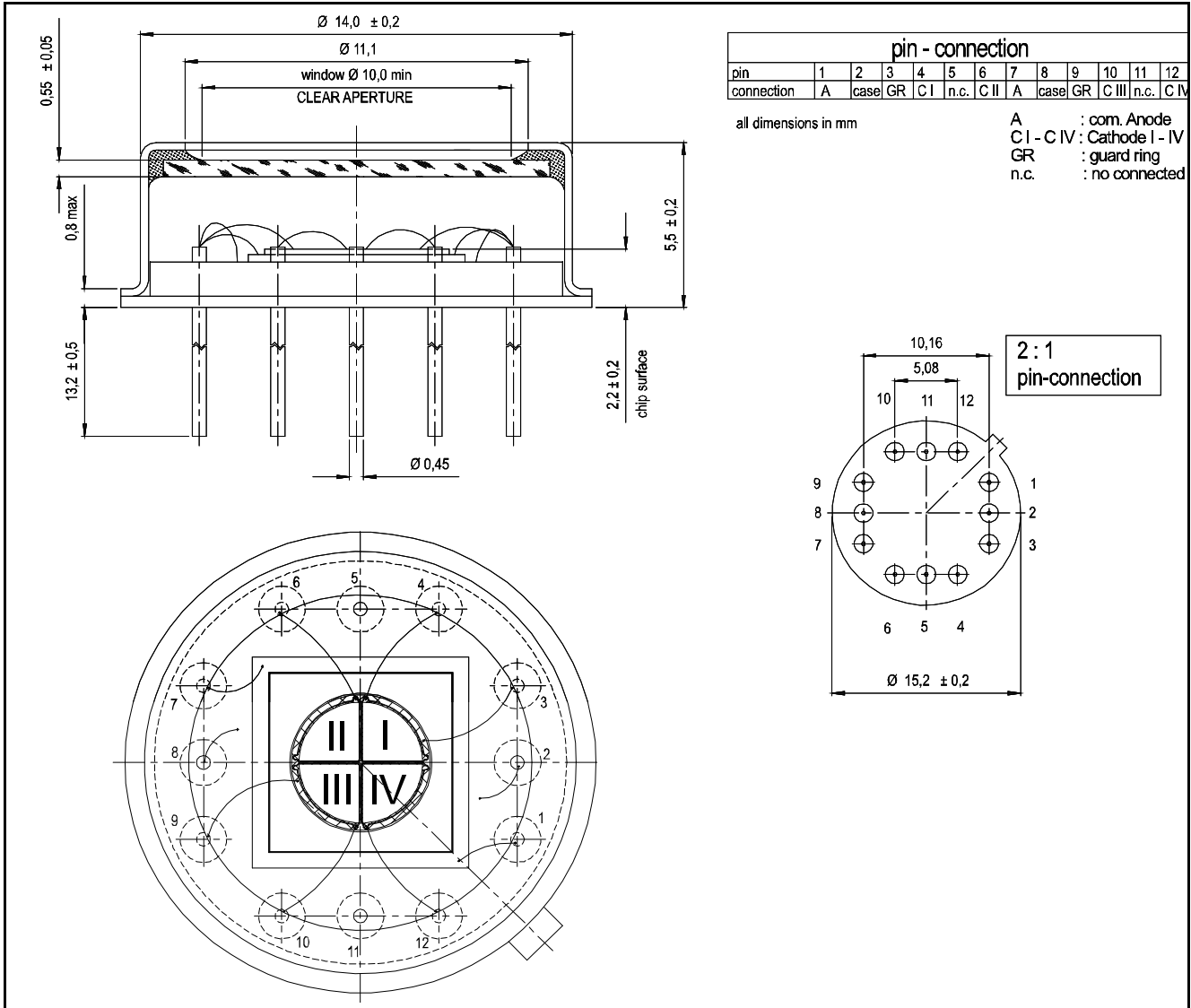

Package dimension

Small quantities: Chips on foam pad, boxed (12 cm x 16.5 cm)

Disclaimer: Due to our strive for continuous improvement, specifications are subject to change within our PCN policy according to JESD46C.

European, International Sales:



International AG

Silicon Sensor International AG
 Peter-Behrens-Strasse 15
 12459 Berlin
 Germany
 Phone: +49-30-6399-2399
 Fax: +49-30-6399-23752
 E-Mail: sales@silicon-sensor.com

USA:



Pacific Silicon Sensor, Inc.
 5700 Corsa Avenue #105
 Westlake Village
 CA 91362 USA
 Phone: +1-818-706-3400
 Fax: +1-818-889-7053
 E-Mail: sales@pacific-sensor.com