

DESCRIPTION

The **QP45-Q-HVSD** is a 1064 nm enhanced quad photodiode array with current-to-voltage amplifiers that provide bottom minus top and left minus right difference signals. Additionally the **QP45-Q-HVSD** provides a signal that is the sum of all four quadrant diode signals. The difference signals are voltage analogs of the light intensity difference sensed by the pairs of photodiode elements in the array. The board has a 7 pin connector attached for easy hook up. Also available without connector.

APPLICATIONS

- Pulsed 1064 nm laser beam centering
- NIR pulsed light positioning and tracking



ABSOLUTE MAXIMUM RATING

SYMBOL	PARAMETER	MIN	MAX	UNITS
T _{STG}	Storage Temp	-15	+100	°C
T _{OP}	Operating Temp	0	+70	°C
V _S	Power Supply Voltage Recommended ±15V	±4.5	±18	V
V _R	Applied Bias Voltage*	30	50	V

CONNECTIONS

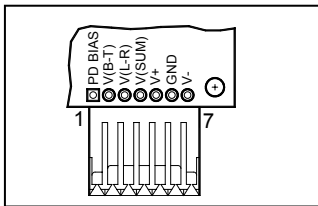

SPECTRAL RESPONSE @ 23°C

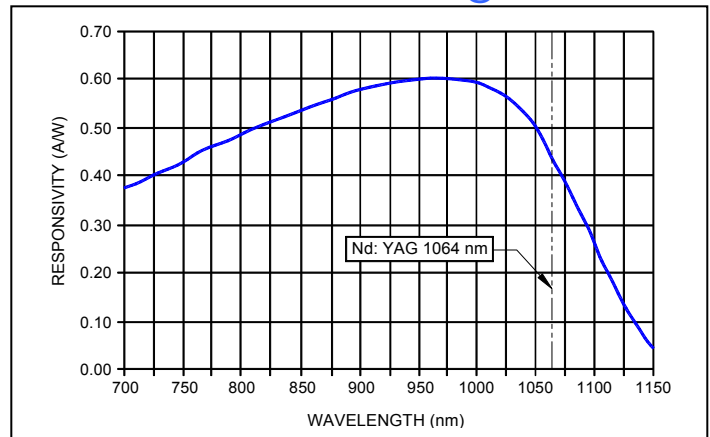

ELECTRO-OPTICAL CHARACTERISTICS @ 22° C

SYMBOL	CHARACTERISTIC	TEST CONDITIONS	MIN	TYP	MAX	UNITS
V _O	Output Voltage (all outputs)		---	+V _S -3	---	V
			---	-V _S +3	---	
I _O	Output Current Limit	V _S = ± 15 V; V _R = 50 V	---	---	25	mA
	Slew Rate	V _S = ± 15 V; V _R = 50 V	---	---	10	V/μs
	Theoretical noise	V _S = ± 15 V; V _R = 50 V	---	15	---	nV/√Hz
Δf _{-3dB}	Bandwidth**	V _S = ± 15 V; V _R = 50 V; λ = 1.06 μm	---	150	---	kHz

* do not apply negative voltages to pad 1.

** dependant on bias voltage

Disclaimer: Due to our policy of continued development, specifications are subject to change without notice.

The **QP45-Q-HVSD** outputs are labeled as B-T for bottom minus top, L-R for left minus right. The output voltages are obtained by routing the diode element currents into current-to-voltage amplifiers with a gain of 10^4 .

$$V_{B-T} = [(I_{3,4}) - (I_{1,2})] \cdot (10^4) \text{ on Pad 2.}$$

$$V_{L-R} = [(I_{2,3}) - (I_{1,4})] \cdot (10^4) \text{ on Pad 3.}$$

$$V_{SUM} = [(I_{1,2,3,4})] \cdot (10^4) \text{ on Pad 4.}$$

$I_{X,Y}$ is the sum of the currents generated by photodiode elements x and y. Looking down through the window of the photodiode, the quadrants are identified in drawing on page one.

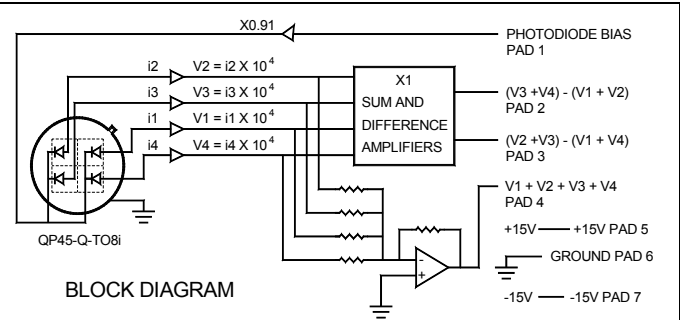

APPLICATION NOTES

Beam Size

The light spot applied to the QP45-Q-HVSD must be smaller than a single element of the photodiode array. The QP45-Q-HVSD has four 3.1 X 3.1 mm active area quadrants. If the light spot is too large, it may be reduced to fit the photodiode array by use of a lens. A decrease in output signal strength is observed as the light spot crosses the separation boundary of the quadrants, usually referred to as the "gap". This effect is more pronounced as the diameter of the light spot decreases, as a larger percentage of the light spot's power falls within the non-active gap. For this reason, the minimum light beam diameter should be a least one millimeter. A lens may be used to increase the beam diameter.

Photodiode Bias Operation

The QP45-Q-HVSD array must be operated in the reverse bias mode. The device will not operate correctly without a reverse bias applied to Pin 1. The minimum recommended reverse bias is 30 volts. Do not connect Pin 1 to negative voltages, as this will forward bias the photodiode array, making it inoperable and possibly damaging the circuit.

Use of Sum and Difference Signals for Alignment

The sum output signal may be used to help preliminary alignment of the QP45-Q-HVSD to the source light beam. First, the beam or the QP45-Q-HVSD is adjusted for maximum sum output signal. Second, the beam or QP45-Q-HVSD is adjusted until the L-R and B-T signals are at minimum. This procedure results in the beam being centered on the quad photodiode array.

Signal Null Detector for Servo Applications

A common application for the QP45-Q-HVSD is a signal null detector as part of a servo system that maintains the position of a light beam. Errors in beam position are reported by the QP45-Q-HVSD and may be used to adjust a positioning device that restores the beam or the beam's source to a null position.

Speed of Response

Increasing the photodiode bias voltage will increase the speed of the QP45-Q-HVSD. As noted above, Pin 1 must supply a positive bias voltage to the quad for basic operation and improved frequency response at longer wavelengths (e.g. 1.06 μm) of illumination. Care should be taken not to exceed the breakdown voltage of the quad photodiode. See Absolute Maximum Ratings on page one for maximum values.

Temperature Considerations

The operation temperature must be between 0 to 70 °C. For best resolution the temperature should be kept at or below 25 °C. Thermal gradients across the detector will cause position errors and should be avoided.

Offsets

Precision components are used in the circuitry but as much as 10 millivolts of offset may still be present in the outputs. If this causes a problem the offsets should be removed externally.

USA:

Pacific Silicon Sensor, Inc.
5700 Corsa Avenue, #105
Westlake Village, CA 91362 USA
Phone (818) 706-3400
Fax (818) 889-7053
Email: sales@pacific-sensor.com
www.pacific-sensor.com

9/15/2009

International sales:

Silicon Sensor International AG
Wilhelmshofstrasse 76-77
D-12459 Berlin, Germany
Phone +49 (0)30-63 99 23 10
Fax +49 (0)30-63 99 23 33
Email: sales@silicon-sensor.de
www.silicon-sensor.de