

### DESCRIPTION

The **DL100-7-PCBA2** is a dual axis position sensing diode with sum and difference amplifiers. It also contains circuitry for applying a bias voltage to the position sensing diode, or the user can externally apply a bias voltage. The DL100-7-PCBA2 has higher gain-bandwidth amplifiers than the DL100-7-PCBA3, enabling it to achieve the same bandwidth with 10 times the gain. The board has a 9 pin connector attached for easy hook up.

Outputs are bipolar voltage analogs of the X and Y position of the light spot centroid, as well as the total X current and the total Y current. The sum outputs may be used to externally normalize the X and Y difference outputs. By normalizing the X and Y signals, they become independent of fluctuations in light spot intensity.

### APPLICATIONS

- NIR & visible pulsed light positioning and tracking
- Laser beam tracking



### ABSOLUTE MAXIMUM RATING

SYMBOL	PARAMETER	MIN	MAX	UNITS
T <sub>STG</sub>	Storage Temp	-15	+100	°C
T <sub>OP</sub>	Operating Temp	0	+70	°C
V <sub>S</sub>	Power Supply Voltage Recommended ±13V	±5	±13	V
V <sub>R</sub>	Applied Bias Voltage*	0	±13	V

### CONNECTIONS

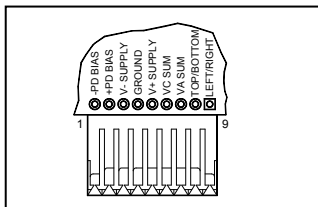

### SPECTRAL RESPONSE @ 22°C

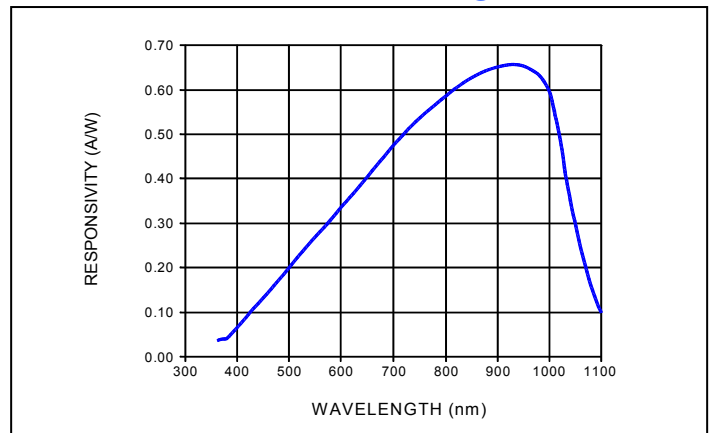

### ELECTRO-OPTICAL CHARACTERISTICS @ 22° C

SYMBOL	CHARACTERISTIC	TEST CONDITIONS	MIN	TYP	MAX	UNITS
V <sub>O</sub>	Output Voltage (all outputs)		---	+V <sub>S</sub> -3	---	V
I <sub>O</sub>	Output Current Limit	V <sub>S</sub> = ± 12 V; V <sub>R</sub> = 0 V	---	---	25	mA
	Slew Rate	V <sub>S</sub> = ± 12 V; V <sub>R</sub> = 0 V	---	---	10	V/μs
	Theoretical noise	V <sub>S</sub> = ± 12 V; V <sub>R</sub> = 0 V	---	15	---	nV/√Hz
Δf <sub>-3dB</sub>	Bandwidth**	V <sub>S</sub> = ± 12 V; V <sub>R</sub> = 11 V; λ = 880 nm	---	250	---	kHz
	Resolution**	V <sub>S</sub> = ± 12 V; V <sub>R</sub> = 11 V; λ = 880 nm	2.0	---	---	μm
	Linearity**	V <sub>S</sub> = ± 12 V; V <sub>R</sub> = 11 V; λ = 880 nm	---	±1	---	% of full scale
	Maximum light intensity	V <sub>S</sub> = ± 12 V; V <sub>R</sub> = 11 V; λ = 880 nm	---	---	1.5	W/cm²

\* actual bias voltage to photodiode: pad 1 voltage times 0.95.

\*\* dependant on bias voltage

Disclaimer: Due to our policy of continued development, specifications are subject to change without notice.

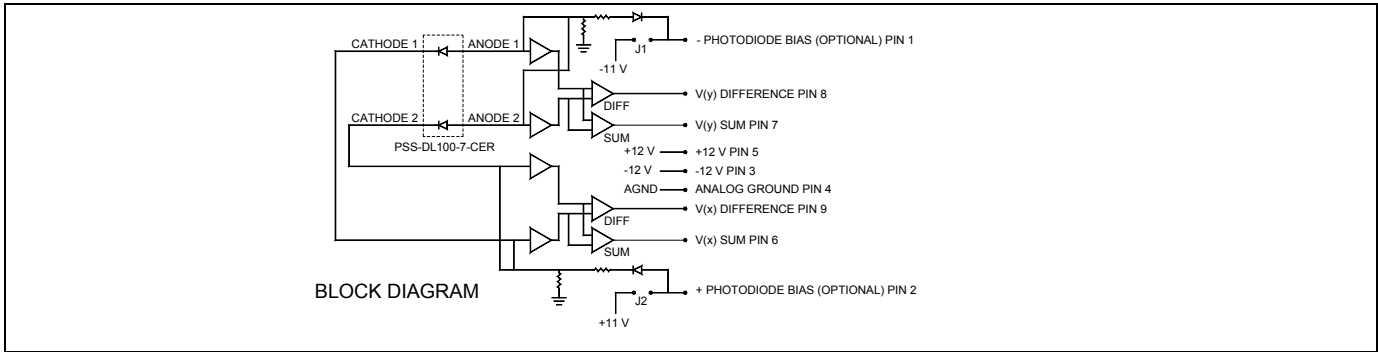

## APPLICATION NOTES

### Description

The DL100-7-PCBA2 is a duolateral position sensing module composed of a 10 mm X 10 mm active area position sensing photodiode and associated circuitry. It senses the position of a light spot on the surface of the photodiode and provides the voltage analogs of the X, Y and spot intensity.

The sensing diode is made using silicon technology and consequently responds to light wavelengths between 400 nm and 1100 nm. The output, as a function of wavelength, follows our typical -7 process silicon photodiode responsivity curve.

### PSD's

Duolateral position sensing diodes are photodiodes with electrodes placed at the edges of the photodiode. Two resistive sheets cover the pn junction, with one sheet on top and one sheet on the bottom. As light impinges on the photodiode, the pn junction generates a current at the centroid of the light power density. The current from this generator separates at the top resistive sheet according to Ohm's law, and electrodes at opposite ends collect the individual currents. The response at the bottom sheet layer is similar to the top sheet except that the current is in the opposite direction. The bottom electrodes are placed at edges orthogonal to the top electrodes.

### Outputs

The DL100-7-PCBA2 module contains amplifiers that convert the light generated currents into voltages. The voltages are then processed to provide a bipolar signal for the X axis and a bipolar signal for the Y axis. The currents are further processed to provide a voltage for the total X current and the total Y current. These voltages represent the light intensity. Note: the X SUM output voltage is negative, the Y SUM is positive.

### PSD Biasing

Position sensing diodes of the type used in the DL100-7-PCBA2 module are more accurate if a reverse bias is applied across the diode. Installing jumpers J1 and J2 will engage circuitry that creates and applies a reverse bias of 11.4 volts (with a +/-12 V supply). In this configuration, there should be no connection to Pins 1 and 2. For bias voltages other than 11.4 volts, remove jumpers J1 and J2 and hook up an external bias source to Pins 1 and 2. (For zero bias operation, just remove jumpers. No connection is necessary to Pins 1 and 2). Although reduced bias will degrade the linearity performance of the PSD, voltage offset and noise can be improved. Determining the optimum bias voltage for each application is usually a "trial and error" procedure. If determining positions over a large area of the PSD is required, the built-in 11.4 volts bias is probably the best option. If low light levels and/or small incremental movement over a small area of the PSD are the application, then zero to low bias voltage may work best.

### Effects of Light Spot Shape, Size and Intensity

Since the photodiode current appears to be generated at the centroid of the light spot power density, it is the centroid location that is tracked by the voltage outputs. If any of the light spot is off the photodiode then the centroid of the light that does fall in the photodiode is the location tracked.

The ultimate resolution of the position sensor is signal to noise limited. Consequently, the spot intensity should be as great as possible without causing damage to the photodiode. There is a limit to the intensity. The spot size and intensity should not concentrate the beam such that the light power locally heats the detector surface above 110 °C. In practice the light intensity should never exceed 1.5 W/cm<sup>2</sup>. Many applications use an intensity of 1 to 3 milliwatts for a spot size of 1 mm<sup>2</sup>.

The current outputs of the photodiode are dependant on the light intensity and as a result the voltage outputs are also dependant on light intensity. If the beam source changes intensity when the spot location is being sensed, then the output should be normalized using the sum signals available on the DL100-7-PCBA2. Normalization is accomplished externally by dividing the location voltage by the sum voltage for the layer (X or Y) being measured. The DL100-7-PCBA2 does not normalize the location output signals.

## Ambient Light Considerations

Ambient light can cause errors and reduced resolution. If the ambient light is of homogenous power density over the entire diode surface it will appear as a current source at the diode center. Since this apparent source adds to the signal current the overall current is increased. The differencing circuits will eliminate this current from the X, Y outputs but it will still be included in the sum circuit outputs.

If the beam to be tracked is monochromatic, or nearly so, a bandpass filter can be placed in front of the diode to eliminate most of the ambient light. If the ambient light contains shadows that fall on the diode surface, the apparent current source will be off center and will contribute to an offset in the position outputs as well as contributing to the sum outputs. Again, an optical filter can eliminate or reduce most of these undesirable effects.

If the ambient light contains shadows that are changing with time then the position outputs and the sum circuit outputs will also show a time varying signal that is related to the shifting ambient light.

## Resolution

Best resolution is obtained with the maximum allowable light intensity and optimum wavelength. The temperature should be held within specification. Resolution obtainable under specified conditions is 2.0  $\mu\text{m}$  or less.

## Speed of Response

Increasing the PSD bias voltage will increase the speed of the DL100-7-PCBA2. The internally created reverse bias of 11.4 volts is sufficient for most applications. As noted above, Pins 1 and 2 are provided to reduce the 11.4 V reverse bias. Care should be taken not to exceed the circuit common mode values and the breakdown voltage of the diode. See Absolute Maximum Ratings on page one.

The rise and fall time of the DL100-7-PCBA2 module with the 1  $\text{cm}^2$  DL100-7-CER diode is better than 5  $\mu\text{s}$ .

## Linearity

Linearity improves with increased reverse bias. The 11.4 V bias provided by the DL100-7-PCBA2 module gives a linearity of  $\pm 1$  percent of full scale or better over the central 80% of the PSD active area.

## Temperature Considerations

The operation temperature must be between 0 to 70  $^{\circ}\text{C}$ . For best resolution the temperature should be kept at or below 25  $^{\circ}\text{C}$ . Thermal gradients across the detector will cause position errors and should be avoided.

## Offsets

Precision components are used in the circuitry but as much as 800 millivolts of dark offset may still be present in the outputs due to 100K gain resistors present in the circuitry. You may have to take this into account when locating zero-zero on the PSD. (Note: this is only when the jumpers are in place. With the jumpers removed, PSD bias voltage drops to zero, and the dark offsets drop to <5 mV, typically <1 mV). If this causes a problem the offsets should be removed externally.

### USA:

Pacific Silicon Sensor, Inc.  
5700 Corsa Avenue, #105  
Westlake Village, CA 91362 USA  
Phone (818) 706-3400  
Fax (818) 889-7053  
Email: [sales@pacific-sensor.com](mailto:sales@pacific-sensor.com)  
[www.pacific-sensor.com](http://www.pacific-sensor.com)



### International sales:

First Sensor AG  
Peter-Behrens-Str. 15  
12459 Berlin, Germany  
Phone +49 (0) 30 / 63 99 23 99  
Fax +49 (0) 30 / 63 99 23 752  
Email: [sales.opto@first-sensor.de](mailto:sales.opto@first-sensor.de)  
<http://www.first-sensor.de>